



Ranger[®] 3000

Compact Bench Scales



The Best Compact Scale in its Class!

The multipurpose Ranger 3000 has all of the capabilities to produce precise results rapidly for a variety of applications. With seven application modes, Ranger 3000 is the ideal scale to meet many industrial weighing needs. Portable and equipped with a rechargeable battery, this scale is beneficial in every corner of the factory and is equipped with functions and features that elevate the Ranger Count 3000 to a class of its own.

Standard Features Include:

- **Largest Display in its Class Makes Ranger 3000 Ideal for Use in All Environments**—Ranger 3000 has the largest display in its class and is equipped with checkweighing LED's and backlit LCD displays which makes it functional in almost any working condition.
- **The Most User Friendly Scale on the Market**—Easy setup leads into even easier use, ensuring that your valuable time is not wasted and you're working as proficiently as possible.
- **Rapid Stabilization Provides Unmatched Throughput**—View your results in just one second, and then see your efficiency, throughput and productivity soar!

Ranger® 3000 Compact Bench Scale

Largest Display in its Class

The inviting display makes Ranger 3000 extremely simple to use. The LCD backlit display is 1.5", 57% larger than displays on other comparable products. Checkweighing LED's provide additional confirmation and clarification of results. The bright display makes Ranger 3000 ideal for use in dim settings.

The Most User Friendly Scale on the Market

Simple menu navigation and dedicated keys make Ranger 3000 the most user-friendly industrial scale on the market. Complete with dedicated TARE key and Yes, No, Back, Exit keys, Ranger 3000 eliminates the need to master complex input commands and allows you to focus on the job at hand.

Rapid Stabilization

Ranger 3000 produces accurate results within one second. Rapid stabilization virtually eliminates your wait time and allows you to move at a pace determined by you and not your weighing equipment. Work efficiently and with confidence that your results are accurate. Maximize your throughput without sacrificing accuracy with the Ranger 3000.

Weigh Below Capability

The easy-to-use and install weigh below hook offers the functionality to perform specific gravity tests. It can also be used to weigh items that cannot be easily lifted on to the weighing pan.

Approvals

The Ranger 3000 has been designed to meet or exceed the Class III accuracy requirements in accordance with the National Institute of Standards and Technology (NIST) Handbook 44.

Standard Connectivity with Flexible Options

Standard RS232 with optional Ethernet, second RS232 and USB offers additional data transfer capabilities and allows connection to multiple peripherals.



Portability and Versatile Power Options

Say goodbye to being restricted to working only near power outlets! With its convenient carrying handle and rechargeable lead acid battery that can provide power for more than 210 hours, Ranger 3000 can provide many hours of uninterrupted operation in the area of your workspace that most conveniently fits your needs. It can also be powered through the easy connect power cord that takes up minimal space and automatically adapts to different power line voltages and frequencies, eliminating disruptions in workflow due to power outages and shortages.



Application Modes

- **Weighing**—Determine the weight of items in the selected unit of measure.
- **Percent Weighing**—Measure the weight of a sample displayed as a percentage of a pre-established Reference Weight.
- **Parts Counting**—Count samples of uniform weight.
- **Check Weighing/Percent/Counting**—Compare the weight/percent/count of a sample against target limits. Choose from Checkweight, Checkpercent or Checkcount.
- **Accumulation**—Totalization of weight, count or percent. Calculates total accumulated weight, count, or percent of separate items.
- **Dynamic Weighing**—Weigh an unstable load. Balance takes an average of weights over a time period.
- **Display Hold**—Manually or automatically holds the last stable weight on the balance display. Activated by setting time interval of Dynamic Weighing to zero.

Outline Dimensions

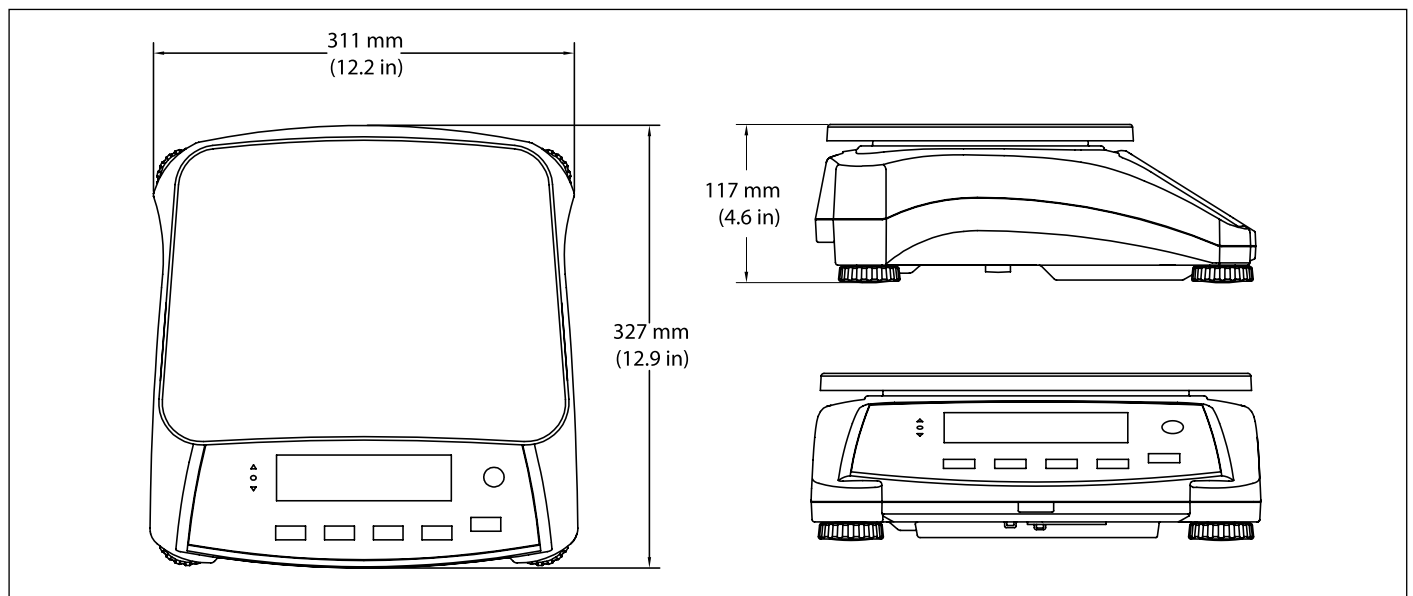

Ranger® 3000 Compact Bench Scale

Model	R31P1502	R31P3	R31P6	R31P15	R31P30
Default Capacity × Readability	1.5 kg × 0.00005 kg 1500 g × 0.05 g	3 kg × 0.0001 kg 3000 g × 0.1 g	6 kg × 0.0002 kg 6000 g × 0.2 g	15 kg × 0.0005 kg 15000 g × 0.5 g	30 kg × 0.001 kg 30000 g × 1 g
Certified Capacity × Readability	1.5 kg × 0.0005 kg 1500 g × 0.5 g	3 kg × 0.001 kg 3000 g × 1 g	6 kg × 0.002 kg 6000 g × 2 g	15 kg × 0.005 kg 15000 g × 5 g	30 kg × 0.01 kg 30000 g × 10 g
Maximum Displayed Resolution	1:30000	1:30000	1:30000	1:30000	1:30000
Construction	ABS housing, stainless steel platform				
Weighing Units	kg, g, lb, oz, lb:oz				
Application Modes	Weighing, Percent Weighing, Parts Counting, Checkweighing, Checkcounting, Checkpercent, Accumulation, Dynamic Weighing/Display Hold				
Display	40 mm high LCD display with white backlight, 6-digit, 7-segment				
Checkweighing Indicators	3 LED (yellow, green, red) with configurable operation and alert beeper				
Keypad	5 mechanical keys				
Zero Range	4% or 20% of full scale capacity				
Tare Range	Full capacity by subtraction				
Stabilization Time	1 second				
Auto-Zero Tracking	Off, 0.5, 1 or 3 divisions				
Safe Overload Capacity	150% of capacity				
Power	100-240 VAC / 50-60 Hz internal universal power supply, internal rechargeable lead acid battery				
Battery Life	210 hours continuous use with 12 hour recharge time				
Calibration	External, with user-selectable calibration weight				
Interface	Built-in RS232, optional 2 nd RS232, USB, Ethernet				
Operating Temperature Range	-10° C to 40° C				
Pan Size (W × L)	300 × 225 mm				
Scale Dimensions (W × L × H)	311 × 327 × 117 mm				
Shipping Dimensions (W × L × H)	397 × 447 × 195 mm				
Net Weight	4.2 kg				
Shipping Weight	5.45 kg				

Other Standard Features and Equipment

ABS housing, stainless steel platform, 210 hours of battery life, 3 LED (yellow, green, red) checkweighing lights with selectable operation and audible signal settings, integral weigh-below hook, transportation handle, sealed front panel, menu lockswitch, up front level indicator, adjustable leveling feet, selectable environmental and auto-print settings, stability indicator, overload and underload indicators, low battery indicator, auto shut-off, auto tare

Approvals

- **Metrology:** OIML/EC 3000e
- **Product Safety:** CAN/CSA-C22.2 No. 61010-1-04; UL Std. No. 61010-1 (2nd Edition)
- **Electromagnetic Compatibility:** FCC, Part 15, Class A; EN61326-1:2006 (Class B); C-Tick
- **Other:** WEEE/ROHS

Accessories

Ethernet Kit	30037447
Second RS232 Kit	30037448
USB Kit	30037449
In Use Cover	30037451
SF40A Impact Printer	Contact Ohaus

OHAUS CORPORATION
www.ohaus.com
ISO 9001:2008
 Registered Quality
 Management System



Proudly Sold & Serviced By:

Able Scale Co Pty Ltd
 Ph: 1300 731 360

21 Green St Thomastown VIC. 3074

find us on the web: www.ablescale.com.au

80774649 © Copyright Ohaus Corporation

